

## INFORMATION SHEET AND USER GUIDE FOR REMOTE POWER SYSTEMS FOR SIGNAL AND DATA CABLING.

ALLOWS REMOTE POWERING OF EQUIPMENT OVER NETWORKS AND TWISTED PAIRS.

MODEL	OUTPUT	MODEL	OUTPUT	MODEL	OUTPUT
SM4490	5V at 3A	SM4493	15V at 1.3A	SM4496	24V at 0.8A
SM4491	9V at 2A	SM4494	18V at 1.1A	SM4498	13.8V at 1.4A (12V float)
SM4492	12V at 1.6A	SM4495	21V at 0.9A	SM4499	27.6V at 0.7A (24V float)

Models SM4498 AND SM4499 may be used to charge lead acid batteries for high short-term surge power.

**GENERAL:** These remote power systems are intended for use wherever equipment needs up to 20W of DC power at the end of a network or signal cable. LP Radio Systems, Surveillance Cameras, etc. are usually supplied with small AC power adapters that supply low voltage DC to the equipment. An AC mains outlet would be needed close to every installation. Remote AC mains outlets are costly and difficult to install, especially in industrial environments.

The following description applies for standard CATEGORY 5 NETWORK CABLING but may be read across to any wiring. The remote equipment connects to the network cabling from a Host or Hub which is always powered from a local AC supply. The network connection uses FCC RJ45 style 8 pin connectors and cable. Only four wires in the 8 wire standard network cable are used for data, leaving four wires spare. These are used to take DC power to the remote equipment using these Remote Power Systems, plugged into the same mains outlet as the Hub. Note that for installations requiring high short-term power (pan and tilt mechanisms), some models allow continuous charging of 12V or 24V lead acid batteries. Models are available that generate 230VAC mains voltage at the remote cable end.

**KIT DESCRIPTION:** The Remote Power System kit (1 per item of equipment) consists of two parts :-

i) The Master unit (SM449xM) is a mains power unit connected between the host network connection and the network cable, allowing connection of low voltage (35V) DC to the four spare network wires arranged as two pairs. FCC RJ45 type inlet and outlet sockets are provided as well as a 2 metre long mains cord for connection to an AC mains outlet. Size is 115mm x 76mm x 61mm.

ii) The Slave unit (SM449xS) is a cable adapter with a step-down switching regulator inside. The Slave is connected between the long network cable and the normal network connection to the remote equipment. It has FCC RJ45 sockets for the network cable to plug into, and for onward connection to the equipment. There is also a power jack on a flying lead which plugs into the power input socket on the equipment. Size is 70mm x 45mm x 28mm.

**CABLING:** In addition to the AC supply to the Master, three direct data cables are required:-

- 1) A short cable from the hub or host to socket PT1 on the Master unit (SM449xM). A standard direct patch cable is suitable. WARNING: Do not plug the host into socket PT2 even for a second, as the host may be damaged.
- 2) A full network cable between socket PT2 on the Master and socket PT2 on the Slave. All 8 wires must be connected. Note that pins (wires) 4, 5, 7 and 8 carry the DC power from Master to Slave.
- 3) A short cable between socket PT1 on the Slave unit (SM449xS) and the Remote Equipment. A standard direct patch cable is suitable.

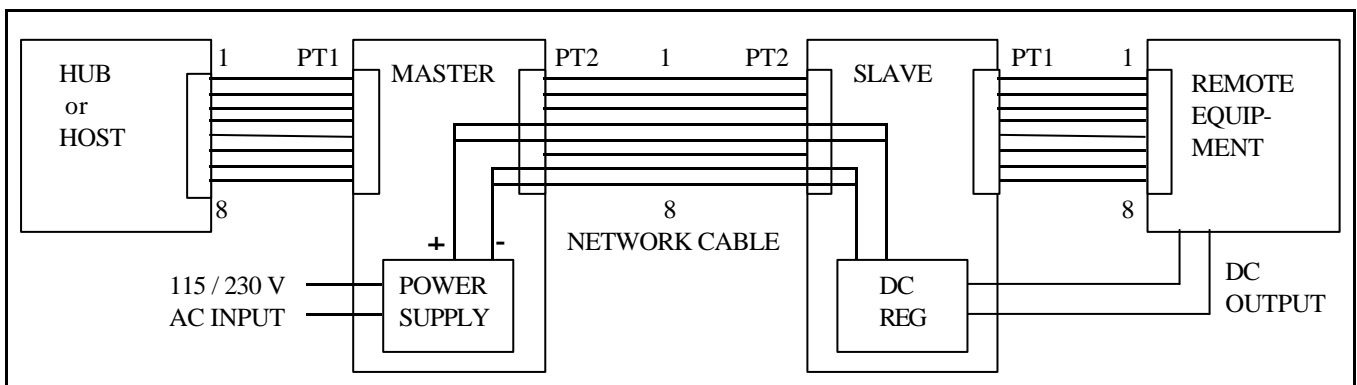

See the SM4500 series for Remote Power Systems that generate 115/230V AC at the remote end.